

# ISISPACE Modular EPS 2

## IMEPS2 Datasheet

ISIS-IMEPS2-DSH-0001, Version 2.0, Released 2024-07-30

Modular and highly configurable power system suitable for CubeSat missions from 3U upwards.

## Applications

The IMEPS2 is a modular power solution, which follows a PC104 form factor, designed as a flexible EPS targeting larger nano- and micro-satellites from 3U upwards. It is available in multiple configurations, supplying 45Wh, 90Wh, 135Wh and more.

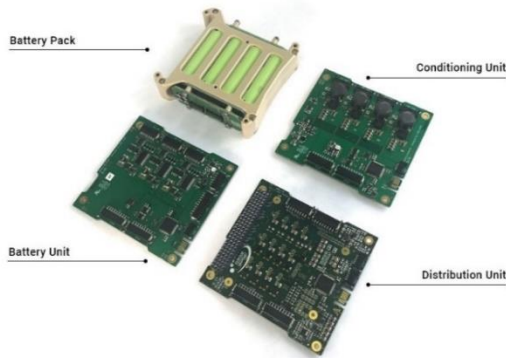

## General Description

The modular Electrical Power Subsystem (EPS) is the second-generation modular EPS, designed and manufactured by ISISPACE. Using recent high-performance technology, the EPS provides improved efficiency over the previous version while minimising EMI. The modular architecture of the system allows tailoring the EPS to specific platform requirements without the need of complete customisation.

The distributed design philosophy that underpins the design allows unprecedented flexibility in output bus count and voltage, and enables tailorable redundancy to be applied for selectable parts of the platform, depending on the needs of the mission.

## Optional Features

### Power Battery Unit & Battery Packs:

- Up to three battery packs (PBP-4S1P) per battery unit board (PBU)
- Each additional PBP adds 45 Wh battery storage
- Multiple PBP's and PBU's can be placed in parallel for redundancy

### Power Conditioning Unit:

- Each additional conditioning unit (PCU) allows for further 4x 39W MPPT channels
- Multiple PCU's can be placed in parallel for redundancy

### Power Distribution Unit:

- Each additional ISISPACE Power Distribution Unit (PDU) allows:
  - 4x switchable output channel at Vbat (12.8V – 16V)
  - 2x user defined voltages (up to 12V)
  - Each user defined voltage has 4x switchable output channel.
  - User definable 'permanent' channels, and fully configurable auto-enable output bus time delays.
- Multiple PDU's can be placed in parallel structure for redundancy.
- Multiple PDU's can have their output channels electrically ordered for supply redundancy.
- Multiple PDU's can be placed in series to create master-slave power chains.

## Key Product Features

- Compliant to CubeSat standard
- Communication over two independent I<sup>2</sup>C or UART interfaces, SPI optional
- FRAM-based MCUs for improved radiation tolerance
- Hardware over-current protection and hardware-based maximum power point tracking
- Hardware Supervisor including Watchdog
- Solar Panel interface utilises GaN-FETs
- Output load channels:
  - Buck regulated power channels
  - Over-current and reverse-current protection in hardware
  - Over-voltage protection through TVS diodes
  - Turn on voltage ramp control (soft start)
  - Software configurable auto enable and latch-off retry enable timings
  - Accurate voltage, current and power sensing on each channel
- Rich housekeeping telemetry is available
- Very low idle consumption when no enabled output channels
- Interoperable with ISISPACE Solar Panels, On-Board Computer and radios

## Flight heritage and quality assurance

- Design based on heritage from ICEPS1 design flown on PEASSS CubeSat (2016).
- IMEPS1, first generation, flown in 2018. IMEPS2 first flown in 2020.
- Qualification Thermal Testing, -40 to +80 °C
- Design qualification load Static +10.8 [g], three axes
- Sine and Random Vibration ASAP5 Qualification Levels
- IPC-A-610 Class 3 PCB, flight units thermally acceptance tested
- PBP-4S1P has deployment heritage from ISS.
- **Contact ISISPACE if you are in need of more detailed heritage information.**

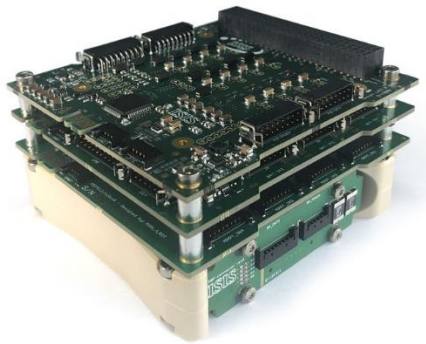

## Related Products

The IMEPS2 belongs to the ISISPACE EPS family of products, including ICEPS2 and IMEPS3 for different sized missions. Other related products are listed below:



- **ICEPS2** – Compact EPS for 1U-3U XL Platforms
- **IMEPS3** – High-Power Modular EPS for CubeSats above 12U, and MicroSats
- **EPS EGSE** – EGSE for Interfacing with ISISPACE EPS units
- **ISPA** – ISISPACE Solar Panels

## Ordering information

- STEP Files available on Website.
- ICDs can be shared on request.
- User Manuals are shared upon purchase.
- EGSE and Stack Frames sold separately.
- Please contact [sales@isispace.nl](mailto:sales@isispace.nl) for ordering information.

## Disclaimer

The contents of this document are subject to the relevant provisions in the contract concluded between the parties. ISISPACE Group ("ISISPACE") shall not be liable, in full or in part, for any damage arising out from the application or use of any product or circuit described herein, in case such application or use are carried out in a manner not in line with the instructions and warranties provided in the User Manual, Safety Manual, product information sheets or any other document provided by ISISPACE upon the delivery of the product ("Documents"). Further, ISISPACE shall not be liable for any damage caused by any use which exceeds the function(s) of the product, or does not conform to such function(s) as described in the Documents. ISISPACE shall not be liable for any damage arising from a use which is not carried out in a manner conforming to acceptable practices in the aerospace industry.

ISISPACE warrants that the product is supplied after relevant tests had shown the product is in good order and functioning, as far as these tests may indicate and predict product functionality.

## System Description

The IMEPS2 sub-assembly consists of four types of sub-system. One or more of these can be combined to form an IMEPS2 Stack:

1. Power Conditioning Unit (**PCU**) – Solar panel input to common power rail
2. Power Battery Unit (**PBU**) – Secondary power storage and retrieval control
3. Power Battery Pack (**PBP**) – Battery holder with integrated fuse
4. Power Distribution Unit (**PDU**) – Power regulation to attached subsystem loads
  - The PDU can be equipped with a DaughterBoard (**PDU\_DB**) to provide more voltage domains.

A quick overview of each of these subsystems is provided below:

### Power Battery Pack (PBP-4S1P)

- Lithium-Ion
- Operating Voltage Vbat: 12.8V – 16.0V
- Storage capacity: 45 Wh per pack (4 cells)
- Battery Pack Configuration: 4 cells in series
- Re-settable fuse per pack

### Power Conditioning Unit (PCU)

- 4x MPPT channels per board
- Maximum Input Current: 3A per channel
- Output Voltage: 16V (other voltages upon request)
- Max Input Power (per channel): 39W (5 series, 6 parallel solar cell strings)
- Telemetry: temperature, per channel input/output current, voltage, power

### Power Battery Unit (PBU)

- Max Input Power: 25.6W at 16V
- Max Output Power: 64W at 16V
- Battery Heating & Balancing
- Telemetry: temperature, per channel input/output current, voltage, power, cell voltage

### Power Distribution Unit (PDU)

- 4x Switchable output channel at VD0 voltage domain (battery: 12.8V-16.0V)
- 4x Switchable output channel at VD1 voltage domain (3V3, 5V or custom up to 12V)
- 4x Switchable output channel at VD2 voltage domain (3V3, 5V or custom up to 12V)
- Max current of 3A per output channel (hardware current limited)
- Max total current of 4A (continuous) and 6A (peak) simultaneously on each VD1 and VD2
- Telemetry: temperature, per channel input/output current, voltage, power

### Power Distribution Unit DaughterBoard (PDU\_DB)

- DaughterBoard provides two additional buck regulators which give 4 independent voltage domains and output channels:
- 1x each VD3, VD4, VD5, VD6 voltage domains (each custom up to 12V)
- Telemetry: temperature, per channel input/output current, voltage, power
- Max current of 3A per output input/output channel.

Each unit is designed to be fully independent, with a design focus on reliability. Reliability can be further increased by doubling up units, providing redundancy. The inter-unit interfaces are minimised and standardised to minimise risk of fault propagation. The standard bus organisation for the common power rail consists of a daisy-chain to minimise required harness length and ease harness routing. Point to point transfer of the power is still possible when this is desired.

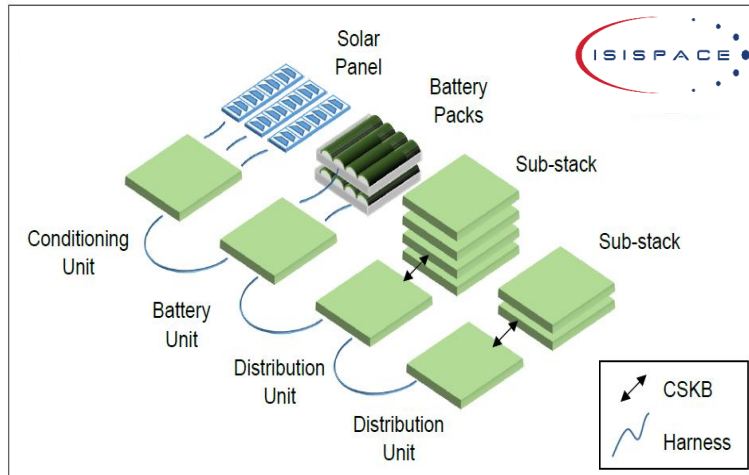

Figure 1 Modular EPS general block diagram

The daisy chain harness includes provisions for the platform I<sup>2</sup>C bus, allowing a distribution unit to supply a stack not only with power but also with the primary platform communications channel. This removes the need for dedicated stack-to-stack interconnect boards for power and platform bus. The distribution unit additionally provides point-to-point connectors for breaking out the most commonly used data signals from the local CSKB, allowing inter-stack CSKB connections to be routed without the need for additional break-out boards.

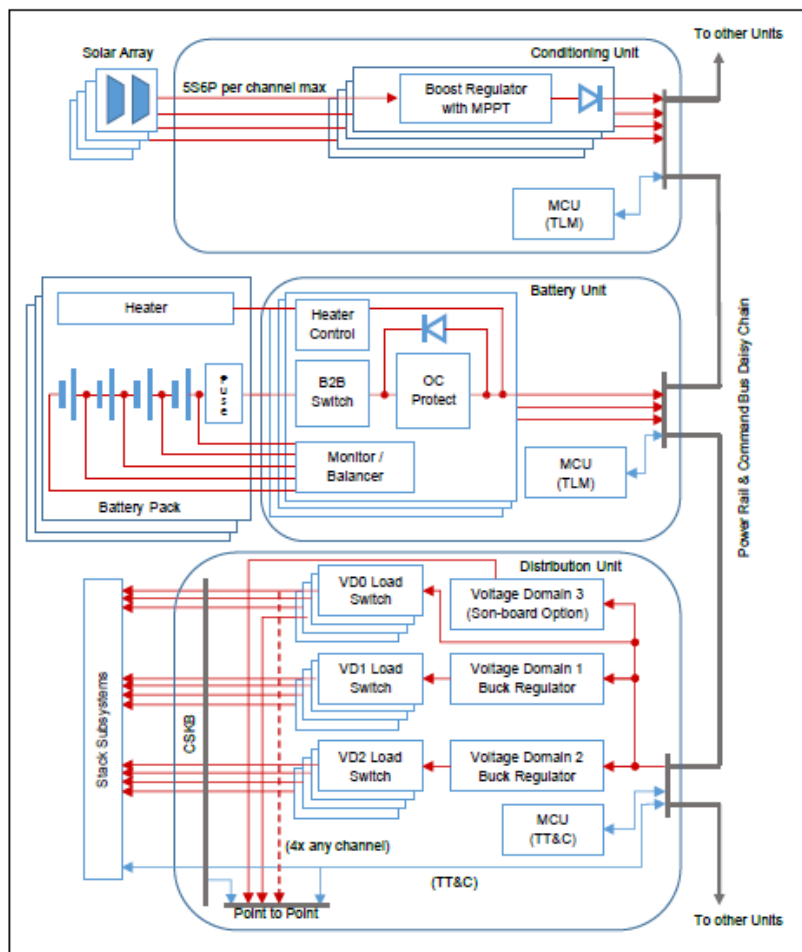
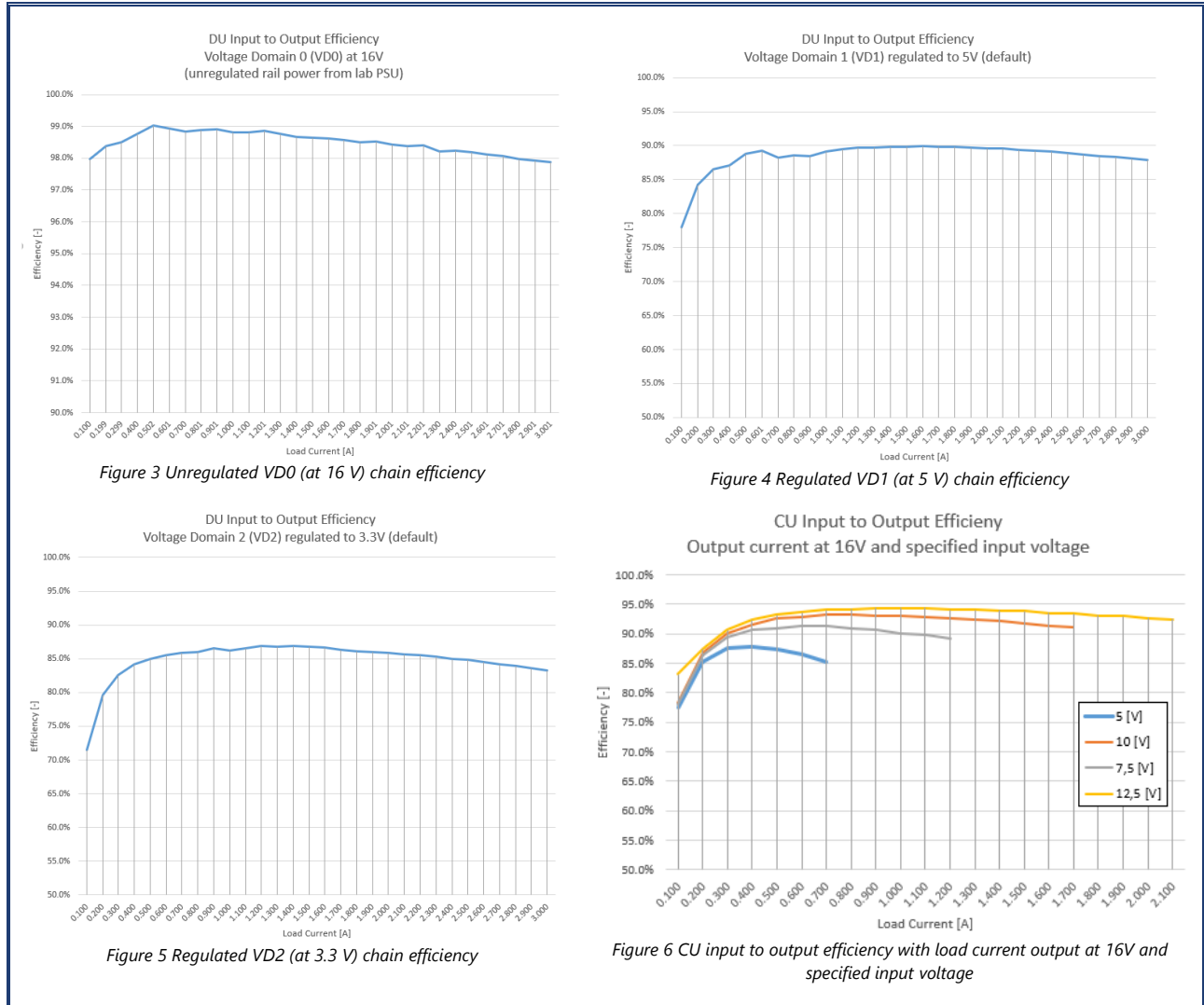

Figure 2 Modular EPS Schematic

The PDU chain efficiency is measured over the entire circuit from RAILA/RAILB input up till CSKB output and includes all board losses. The efficiencies are separately measured for each voltage domain, which are shown in Figure 3 through Figure 6.



In Figures 4-6, losses are due to Ohmic losses and the static consumption of the control circuitry. The lower efficiency at lighter loads is due to the static consumption. In Figure 3, losses are due to Ohmic losses and the static consumption of the control circuitry. The lower efficiency at lighter loads is due to the static consumption.

## Electrical Specification

Table 1 IMEPS2 Specification

Parameter	Value	Unit	Comment
<b>Environmental Characteristics</b>			
Operational temperature	-40 to +70(a)	°C	
Storage temperature	-40 to +85(a)	°C	
Storage lifetime	12	months	
<b>Common Power Rail</b>			
Rail Voltage	12.8 – 16.0	V	
Rail Maximum Current	~12	A	
Harness Interconnect	multicore wire, Harwin M80 L-Tek	-	
Board Interconnect Topology	Daisy Chain, Point to Point	-	
<b>Power Distribution Unit (PDU)</b>			
Height	11	mm	
Weight	51.6 g (incl. top mount full CSKB) 57.4 g (incl. bottom mount full CSKB)	g	
Idle consumption	66 (4.1mA @ 16V)	mW	(regulation of VD1 at 5V and VD2 at 3.3V, no external load)
Input maximum current	8	A	
Output Regulator Topology	Buck only.	-	Buck or boost regulator or customisation possible on PDU_DB.
Output Regulator Modes	Fixed frequency (loads >= 1A) Burst mode (loads < 1A)	-	Design adapted for low EMI as verified by test.
Output voltage domains	VD0: fixed (= rail voltage) VD1: user selectable (only below rail voltage) VD2: user selectable (only below rail voltage)	-	VD1 and VD2 default configuration is 5V and 3V3 respectively
Output channels	VD0: x 4 VD1: x 4 VD2: x 4 Option using DaughterBoard mounted regulator: VDx: x 4	-	
Output maximum current	Max 3A per channel (limited by OC protection) Max total for VD1: 4A (continuous), 6A(peak) Max total for VD2: 4A (continuous), 6A(peak)	-	

Parameter	Value	Unit	Comment
Electrical Protection	<ul style="list-style-type: none"> <li>- Overcurrent/thermal limit on Unit input</li> <li>- Overvoltage protection on all domains</li> </ul> <p>On each output bus channel:</p> <ul style="list-style-type: none"> <li>- Overcurrent/thermal protection</li> <li>- Voltage ramp slew rate control</li> <li>- Reverse current protection</li> </ul>	-	
Functional Protection	<ul style="list-style-type: none"> <li>- Safety Mode (when VD0 low)</li> <li>- Emergency Low Power Mode (when VD0 low)</li> <li>- Hardware Supervisor including Watchdog</li> <li>- TT&amp;C Watchdog (stack reset on EPS comms timeout)</li> </ul>	-	
Monitoring	<ul style="list-style-type: none"> <li>- MCU/PCB temperature</li> </ul> <p>Voltage, current and power measurements on:</p> <ul style="list-style-type: none"> <li>- Total unit input</li> <li>- Total output for VD0</li> <li>- Total output for VD1 regulator</li> <li>- Total output for VD2 regulator</li> <li>- Each output bus channel</li> </ul> <p>Voltage on:</p> <ul style="list-style-type: none"> <li>- Local board power supply</li> </ul>	-	
Communication bus	<p>I2C, UART, SPI optional.</p> <p>Single wire command only interface.</p> <p>Each Unit provides an isolated I2C bus segment to its stack, separated from the other Units.</p>	-	
<b>Power Battery Pack (PBP-4S1P)</b>			
Height	21	mm	
Weight	252	g	
Battery cell chemistry	Lithium-Ion	-	
Battery cell nominal voltage	3.6	V	
Battery cell min/max voltage	2.5 min, 4.2 abs max	V	
Battery cell capacity	3200	mAh	
Battery cell max output current	6.4	A	
Battery pack configuration	4 series	-	
Battery pack nominal voltage	14.4	V	
Battery pack min/max voltage	10 min, 16.8 abs max	V	
Battery pack operating voltage	12.8-16.0	V	



Parameter	Value	Unit	Comment
Battery pack nominal capacity	3200	mAh	
Battery pack max input current	1.6	A	
Battery heater resistance	100	Ohm	
Battery heater power	160 (16V @ ~2.5W)	mA	
<b>Power Battery Unit (PBU)</b>			
Height	10	mm	
Weight	48.7	g	
Idle consumption	63 (3.9mA @ 16V)	mW	
Battery Channels/Packs per BU	Minimum packs:1 Maximum packs: 3 Individual parallel battery channels available: 3	-	
Battery Channel max output current	4	A	Connecting single battery pack to multiple parallel BU channels possible. Provides current sharing and/or redundancy
BU max input power (per battery channel/pack)	19.2W @ 12V / 25.6W @16V	W	
BU max output power (per battery channel/pack)	48W @ 12V / 64W @16V	W	
Functional Protection	- Emergency Low Power Mode (when string voltage low) - TT&C Watchdog (unit reset on comms failure, does not interrupt power provision)	-	
Monitoring	Per cell voltage Total input/output current, voltage and power 2 x temperature sensors per pack	-	
Battery balancing	Yes, per pack closed loop controlled in orbit configurable: enable/disable, voltage thresholds	-	
Battery heating	Yes, per pack closed loop controlled in orbit configurable: enable/disable, voltage thresholds	-	
<b>Power Conditioning Unit (PCU)</b>			
Height	12	mm	
Weight	58	g	
Idle consumption	MPPT: 33.1mA @ 10V, 0.331 W MCU: 3.9 mA @ 16 V, 0.066 W	-	MPPT circuitry power taken from attached solar panels (sunlight only). MCU circuitry power taken from internal EPS power rail (sunlight and eclipse).
Output Regulator Topology	Boost only	-	
Harvesting Mechanism	Maximum Power Point Tracking	-	

Parameter	Value	Unit	Comment
PV input min/max voltage	2V min, 13V max (with battery voltage > 14V)	V	
Maximum input current	3	A	
Output voltage	16	V	
CU max input power (per channel)	39 (5 series, 6 parallel solar cells strings)	W	
Channels per CU	4	-	
Electrical Protection	- Overvoltage protection - Reverse current protection	-	
Functional Protection	- TT&C Watchdog	-	
Monitoring	- MCU/PCB temperature  Voltage and current on: - Channel input  Voltage, current and power on: - Channel output	-	
Battery dependency	None. Unit can produce power with or without a battery on the output, allowing sunlight-only platform configurations.	-	

## Grounding Scheme

Each of the IMEPS2 boards allows placement of resistors and/or filtering capacitor arrangements between the board ground and the chassis mounting holes.

By default the IMEPS2 is not connected to chassis anywhere, with two exceptions:

1. A high ohmic bleed resistor is located on (each) Battery Unit allowing any chassis developed potential to bleed off into the system ground at the battery.
2. A pair of capacitors connects the power and ground to chassis at the Conditioning Unit input as part of a pi-filter providing common mode and differential mode filtering.

To control EM noise from returning over the solar panel input harness to the outside of the satellite, forming a circuit with the chassis, a pi-filter setup is used. The common mode and differential mode bypass capacitors are placed on the Conditioning Unit, while the inductor bead is either added in the harness or mounted on the solar panel side.

The daisy chain harness and internal board circuitry will impose a finite resistance to currents, causing limited voltage drops across them. This will result in ground level shifts between the grounds of substacks. The effect is schematically shown in Figure 3. Here the battery unit has been arbitrary selected as the 'official' platform GND. Each hop along the daisy chain incurs a voltage difference ('dV') with respect to the GND, its magnitude mainly depending on the current moving through the harness and the harness length.

Mitigations to keep dV small:

- minimise current flow through a single harness
  - distribute loads evenly on both sides of the battery unit
  - split battery packs across multiple DUs at different locations in the daisy chain
- minimise harness length
  - attach battery units directly to distribution units servicing heavy loads

It is particularly important to be aware of the ground level difference when inter-substack digital communication will take place. When distribution units are arranged the preferred way (with heavy loads closest to the battery, light loads attached next), the GND levels of the two substacks will be close together due to the limited current flow between the two substacks. In cases the GND level between substacks cause communication issues a galvanic isolation strategy should be employed.

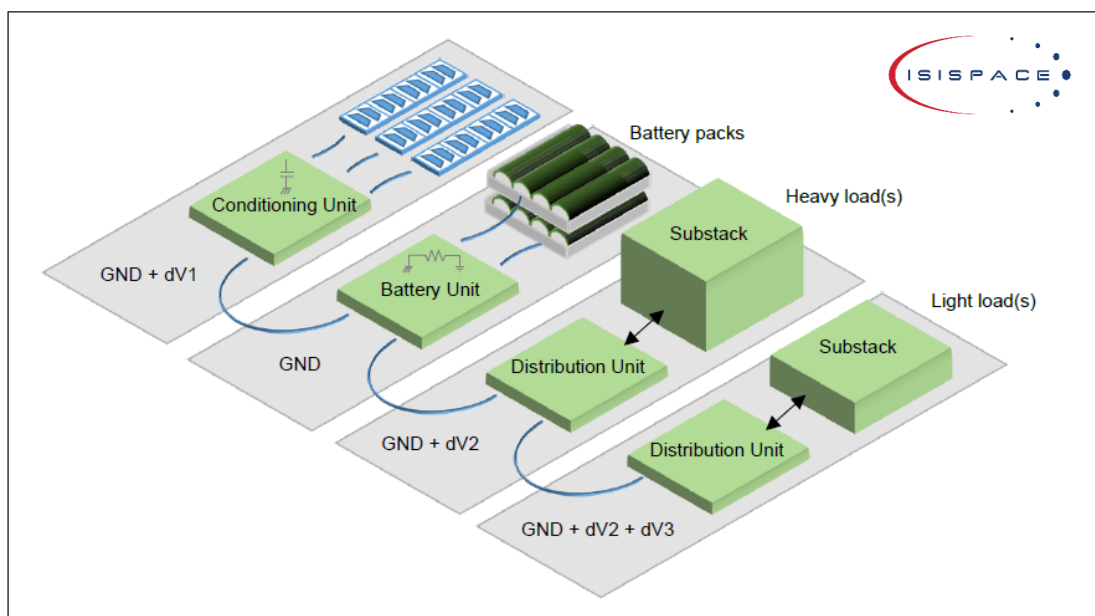

Figure 7 Modular EPS Grounding